

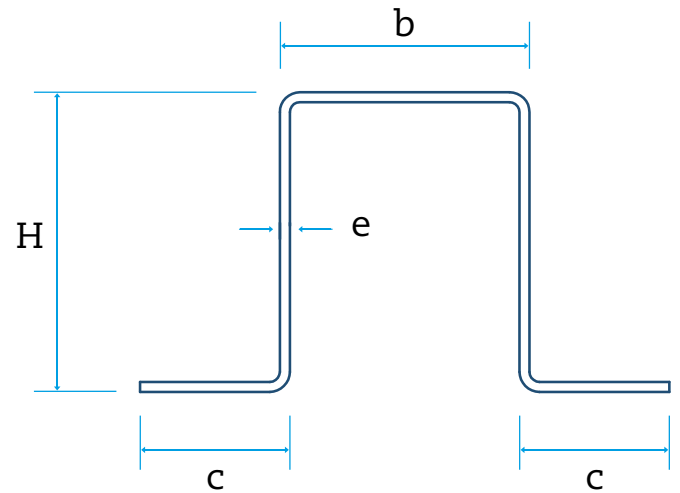

OMEGA profile

H (mm)	b min. (mm)	C (mm)	e (mm)
30	30	de 15 a 35	de 1,5 a 3
40	40	de 15 a 35	de 1,5 a 3
50	40	de 15 a 35	de 1,5 a 3
60	40	de 15 a 35	de 1,5 a 3
80	50	de 15 a 35	de 1,5 a 3
100	50	de 15 a 35	de 1,5 a 3



H (mm)	70 / 80 / 90 / 100
b min. (mm)	30 / 40
C (mm)(mm)	15 a 40
e (mm)	1,2 a 2

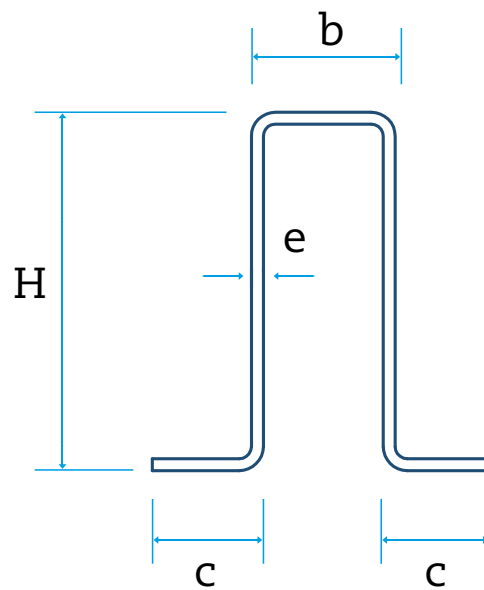

OMEGA SILO profile

Manufacturing possibilities
a: 80 mm - 150 mm
e: 2 / 2,5 / 3 mm

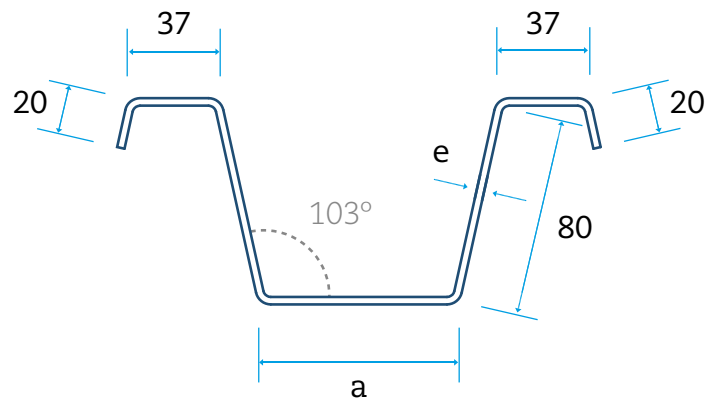

SOPORTE profile

Thick-ness (mm)	Weight (kg/ml)	I _y (cm ⁴)	I _z (cm ⁴)
1,5	4,90	65,22	83,99
1,6	5,20	69,17	89,38
1,8	5,82	76,93	100,08

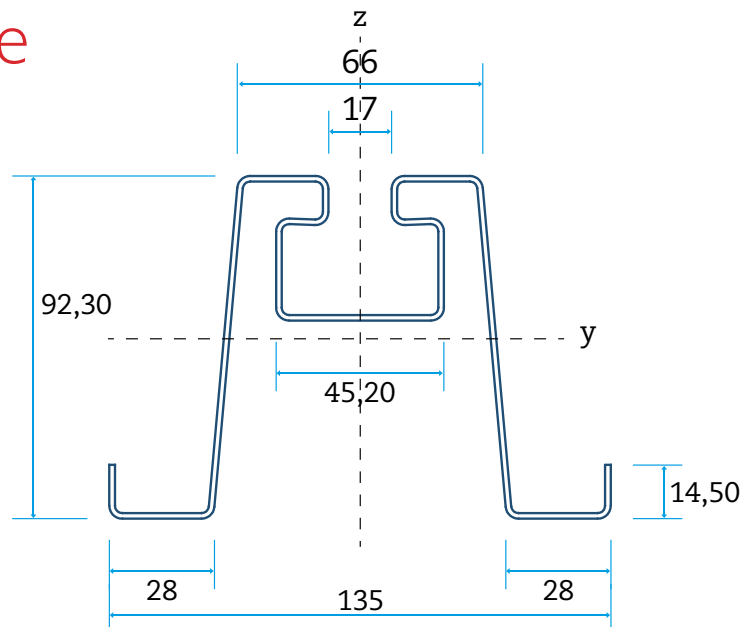

* For tables with mechanical characteristics, contact BRAUSA.
For selections not included please consult manufacturing possibilities.